

QLPD-X

CLAMPING PINS

On Request 

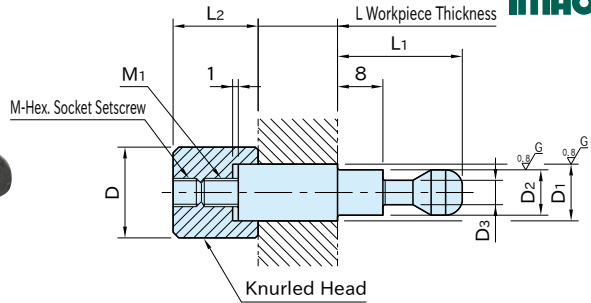



L dimension is adjustable by ± 1 mm to fit actual workpiece thickness.

Shank	Head
SCM435 steel Induction hardened(taper seat) Precision ground	S45C steel Quenched and tempered Black oxide finish

Part Number	D ₂ (f7)	D ₁ (f7)	L* (By 0.1 mm)	D	L ₂	L ₁	D ₃	M
QLPD150-5X 5- (L Dim. in mm)	5	5	$3 \leq L \leq 50$	10	10	17	3	M3×0.5-4L
QLPD150-5X 6- (L Dim. in mm)		6						
QLPD200-8X 8- (L Dim. in mm)	8	8	$4 \leq L \leq 80$	16	15	22	4.3	M5×0.8-5L
QLPD200-8X10- (L Dim. in mm)		10						

Part Number	M ₁	Weight (g)	Pull Clamps
QLPD150-5X 5- (L Dim. in mm)	M3×0.5	min. 8~max.16	QLPD150Series
QLPD150-5X 6- (L Dim. in mm)		min. 8~max.19	
QLPD200-8X 8- (L Dim. in mm)	M5×0.8	min.30~max.60	QLPD200Series
QLPD200-8X10- (L Dim. in mm)		min.31~max.77	

*) For ordering, specify workpiece thickness.

How To Use

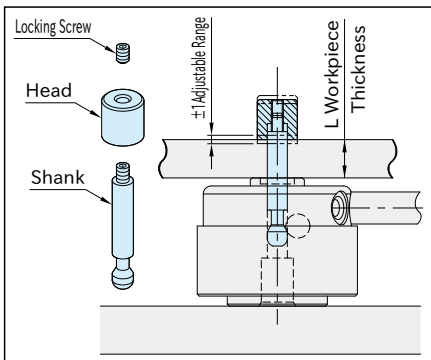

Note

The length of L dimension should be decided depending on the workpiece thickness.

Ordering Example

QLPD150-5×5-10.5

Shank Size

L Dim.

※ QLPD150-5×5 for 10.5mm thickness workpiece.