

TBU

钢球组件(螺丝型)



TBU-S 12025~16050
(锯齿型)



TBU-S 20030~24080
(锯齿型)



TBU-F 12025~16050
(平面型)



TBU-F 20030~24080
(平面型)



TBU-E 12025~16050
(树脂型)



TBU-E 20030~24080
(树脂型)

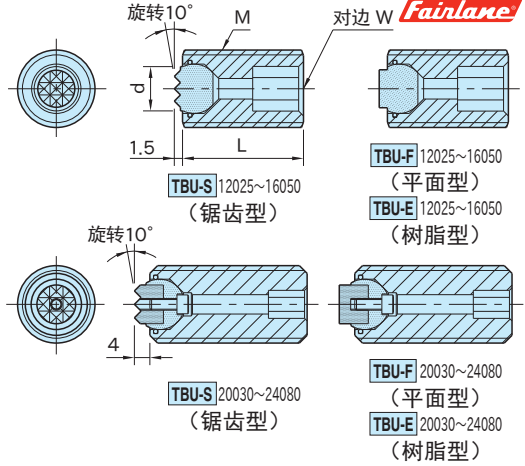

类型	本体	球	衬垫
TBU-S 12025~16050 TBU-F 12025~16050		SKH51 淬火回火 四氧化三铁膜 HRC60	
TBU-E 12025~16050		聚缩醛 白色	
TBU-S 20030~24080 TBU-F 20030~24080	SCM440 淬火回火 四氧化三铁膜 HRC45	SUS440	SKH51 淬火回火 四氧化三铁膜 HRC62
TBU-F 20030~24080			SNM220 渗碳淬火 四氧化三铁膜 HRC60
TBU-E 20030~24080			聚缩醛 白色

★One Point
衬垫直径 φ6~12

锯齿型		平面型		树脂型		M	L	d	W	容许载荷 (kN)注)
型 号	质量(g)	型 号	质量(g)	型 号	质量(g)					
TBU-12025-S	13	TBU-12025-F	13	TBU-12025-E	12	M12×1.75	25	6	6	5.3
TBU-12035-S	19	TBU-12035-F	19	TBU-12035-E	18		35			
TBU-12050-S	28	TBU-12050-F	28	TBU-12050-E	27		50			
TBU-16025-S	26	TBU-16025-F	26	TBU-16025-E	25	M16×2	25	8.5	8	10.9
TBU-16035-S	39	TBU-16035-F	39	TBU-16035-E	38		35			
TBU-16050-S	58	TBU-16050-F	58	TBU-16050-E	57		50			
TBU-20030-S	57	TBU-20030-F	57	TBU-20030-E	53	M20×2.5	30	10	10	18.4
TBU-20050-S	90	TBU-20050-F	90	TBU-20050-E	86		50			
TBU-20070-S	123	TBU-20070-F	123	TBU-20070-E	119		70			
TBU-24040-S	113	TBU-24040-F	113	TBU-24040-E	107	M24×3	40	12		24.5
TBU-24080-S	210	TBU-24080-F	210	TBU-24080-E	204		80			

注)不包括树脂型。

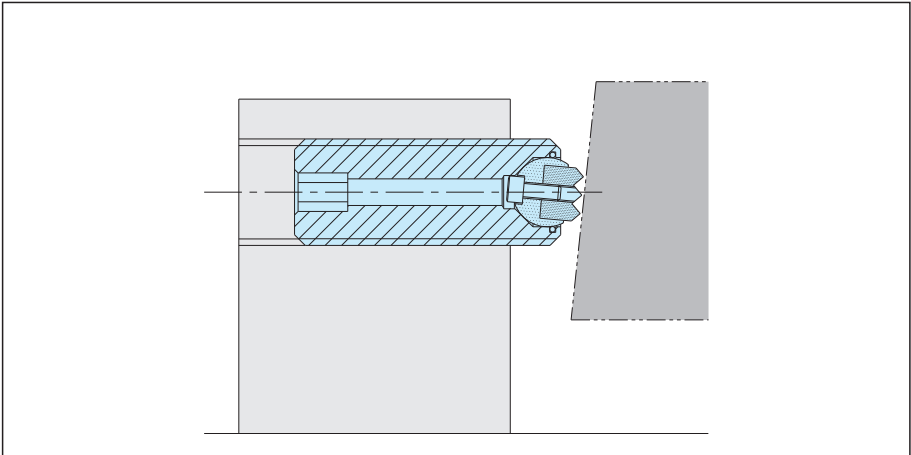

作为夹紧器或限位器使用。

注意事项

衬垫的安装

TBU-S]20030~24080、TBU-F]20030~24080、TBU-E]20030~24080
的衬垫，球从背面推出，请用附件内六角螺栓安装。

衬垫的交换

以下产品通过拆卸安装衬垫用螺栓，可进行衬垫交换。

本体型号	衬垫型号 (参照P.470)	本体型号	衬垫型号 (参照P.467)	本体型号	衬垫型号 (参照P.467)
TBU-20030-S	HS-100	TBU-20030-F	SRP-100	TBU-20030-E	DRP-100
TBU-20050-S		TBU-20050-F		TBU-20050-E	
TBU-20070-S		TBU-20070-F		TBU-20070-E	
TBU-24040-S	HS-120	TBU-24040-F	SRP-120	TBU-24040-E	DRP-120
TBU-24080-S		TBU-24080-F		TBU-24080-E	