

ST-VTC207

垂直式肘节夹具、垂直式肘节夹具(带安全机构)

RHS SUS

STEEL-SMITH®
Clamps on the go... that never let go!



ST-VTC207U



ST-VTC207U-L



ST-VTC207U-S



ST-VTC207S

类型	本体	夹臂	握把	螺栓、螺母	衬垫
ST-VTC-U	SPCC 镀锌	SPCC 镀锌	聚氨酯薄膜	SUM41 镀锌	氯丁二烯橡胶 (CR)
ST-VTC-S	镀锌	SM400A 镀锌			
ST-VTC-U-S	SUS304L 电解研磨	SUS304L 电解研磨		SUS304 电解研磨	

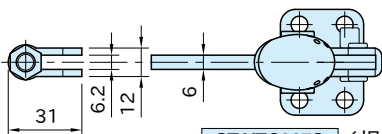
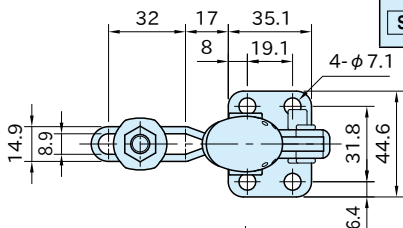

ST-VTC207S (焊接型)

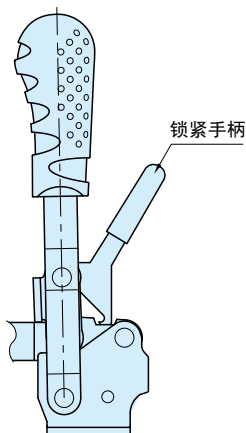
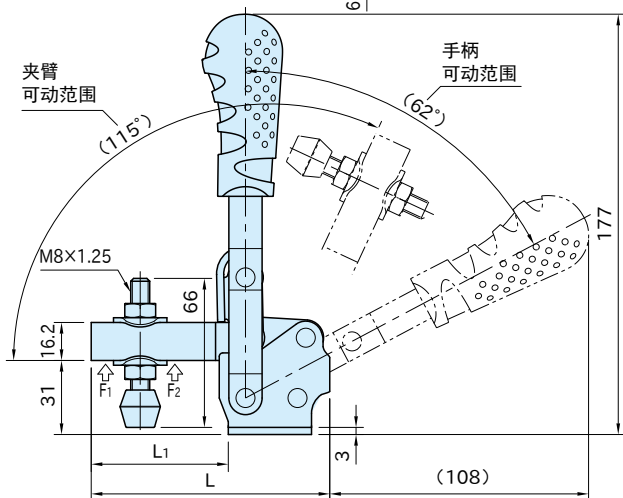

ST-VTC207U-L
(带安全机构)

ST-VTC207U

ST-VTC207U-S

型号	L	L ₁	保持力		质量 (g)
			F ₁ (kN)	F ₂ (kN)	
ST-VTC207U					380
ST-VTC207U-L	100	57.5	1	1.7	390
ST-VTC207U-S					380
ST-VTC207S	98	55	1.5	2.1	380

特点

ST-VTC207S 可以根据需要调节夹臂长短，切短夹臂的长度后，把夹口焊接到夹臂上。