

# ST-VTC201

## 垂直式肘节夹具

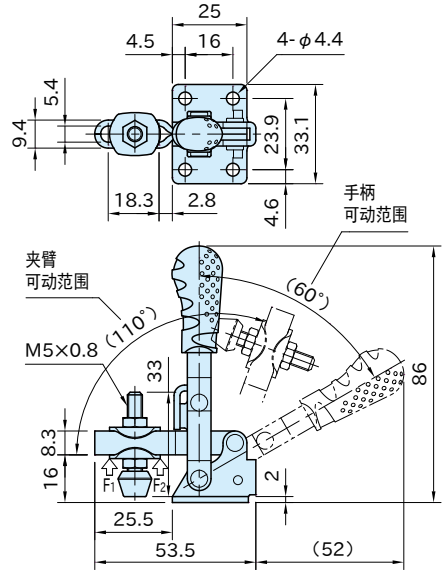

型号	本体	握把	螺栓、螺母	衬垫
ST-VTC201U	SPCC 镀锌	聚氯乙烯薄膜	SUM41 镀锌	氯丁二烯橡胶 (CR)
ST-VTC201U-S	SUS304L 电解研磨		SUS304 电解研磨	

型 号	保持力		质量 (g)
	F <sub>1</sub> (kN)	F <sub>2</sub> (kN)	
ST-VTC201U	0.24	0.5	80
ST-VTC201U-S			