

ST-PAH1725

侧拉式肘节夹具

ROHS **SUS**

STEEL-SMITH®
Clamps on the go... that never let go!



ST-PAH1725



ST-PAH1725-S

型号	本体	握把	U形螺栓
ST-PAH1725	SPCC 镀锌	聚氯乙烯薄膜	SUM41 镀锌
ST-PAH1725-S	SUS304L 电解研磨		SUS304 电解研磨

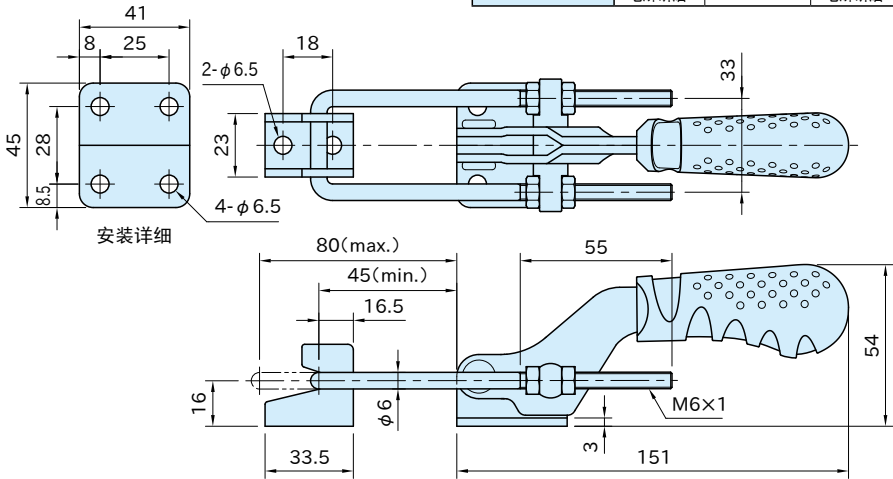

型 号	保持力 (kN)	质量 (g)
ST-PAH1725	3.4	370
ST-PAH1725-S		