

ST-H215,ST-H225 水平式肘节夹具

RHS SUS

STEEL-SMITH®
Clamps on the go... that never let go!

NEW型号
红色标记



类型	本体	握把	螺栓、螺母	衬垫
ST-H-U	SPCC 镀锌	聚氯乙烯薄膜	SUM41 镀锌	氯丁二烯橡胶 (CR)
ST-H-U-S	SUS304L 电解研磨		SUS304 电解研磨	

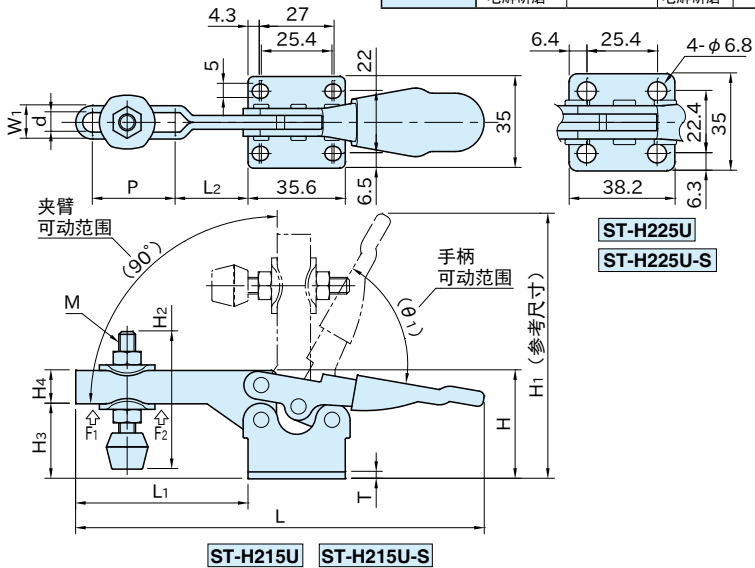

型号	θ_1	M	H ₂	H ₃	d	P	L	H	L ₁
ST-H215U	78°	M6	55	27	7	33	148	39	63
ST-H215U-S									
ST-H225U	66°	M8	66	34	8.5	33	178	47	73.5
ST-H225U-S									

型号	T	L ₂	H ₁	H ₄	W ₁	保持力		质量 (g)
						F ₁ (kN)	F ₂ (kN)	
ST-H215U	2.5	24.5	96	12	12	0.5	1	150
ST-H215U-S								
ST-H225U	3	33	116	13	14.5	1.1	2.2	260
ST-H225U-S								