

使用示例及使用方法

■ 安装孔加工方法

· 定位销的安装孔加工尺寸

AMWF-L-S (螺丝配管)

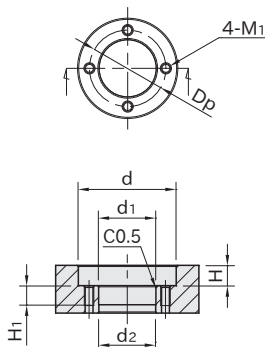

AMWF-L-S-G (座垫配管)

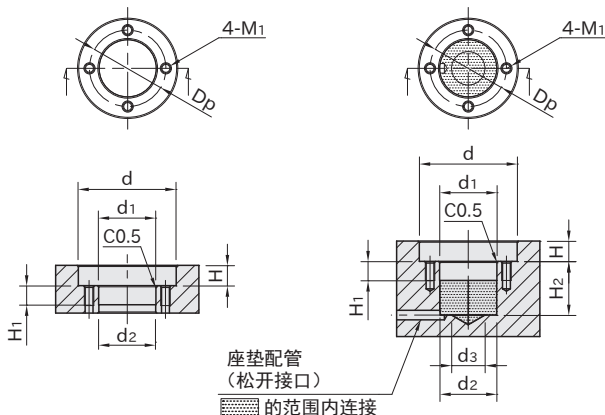

型 号	d ₁ (H7)	H ₁	d ₂	H ₂	d ₃	d	H (±0.05)	M ₁	D _p
AMWF18L-4S	24	8.5	23.8	—	—	41	8.5	M4×0.7深 8	32
AMWF26L-4S	32	9	31.8	—	—	52	10	M5×0.8深10	41
AMWF18L-4S-G	24	8.5	23.8	25.5	14	41	8.5	M4×0.7深 8	32
AMWF26L-4S-G	32	9	31.8	26.5	20	52	10	M5×0.8深10	41

· 定位套的安装孔加工尺寸

AMWF-BU (定位套)

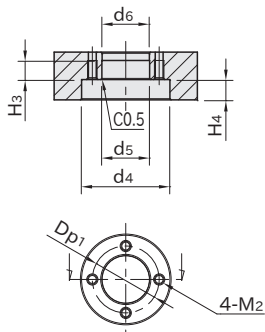

■ 加工精度

AMWF-BU (定位套)

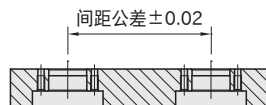

AMWF-L-S (螺丝配管)

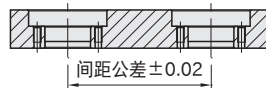

AMWF-L-S-G (座垫配管)

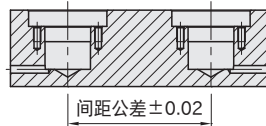

型 号	d ₅ (H7)	H ₃	d ₆	d ₄	H ₄ (±0.05)	M ₂	D _{p1}
AMWF18-BU	20	8	19.8	37	8.5	M4×0.7深 8	28
AMWF26-BU	25	7.5	24.8	45	10	M5×0.8深10	34