

CP159

圆柱套

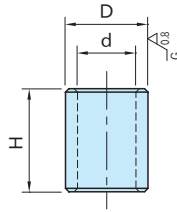

本体
SK95 淬火回火 四氧化三铁膜 精密研磨

型号	d	D (h6)	H	质量 (g)	适用成套夹紧器
CP159-06001	6	8	11	2	CP152-06032
CP159-08001	8.5	12	15	7	CP152-08050
CP159-12001	12.5	18	22	22	CP152-12080
CP159-16001	16.5	22	28	35	CP152-16100

使用示例及使用方法

请用于 **CP152** 成套夹紧器(单型)的底板定位。
(参照P.206)

底板的孔加工图

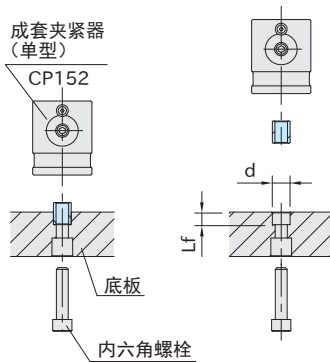

型号	d (H7)	Lf
CP159-06001	8	6.5
CP159-08001	12	8.5
CP159-12001	18	12.5
CP159-16001	22	16.5

相关产品页

- **CP152** 成套夹紧器(单型)(参照P.206)
- **CP155-L** 圆锥夹紧螺栓(基准型)(参照P.208)
- **CP155-D** 圆锥夹紧螺栓(菱型)(参照P.208)
- **CP156** 夹紧螺栓(参照P.210)

底板孔间距公差

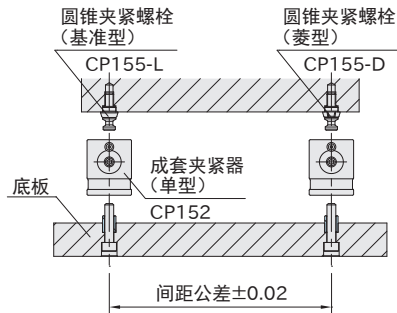

使用示例

