

BRDN

轴承座(直接安装型)

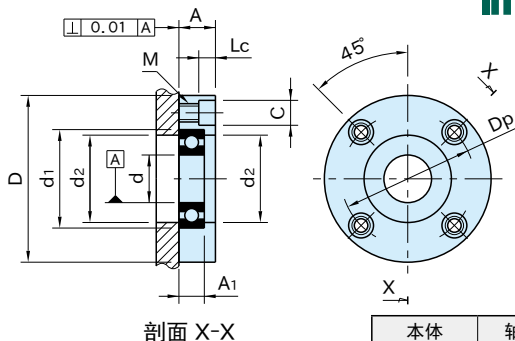

剖面 X-X

本体	轴承
S45C 无电解镀锌	钢铁

型号	轴承型号	d	D	A	M	C	Lc	Dp	d ₁ (H7)	d ₂	A ₁
BRDN2610	6000ZZ	10	55	10	M 5×0.8 (底孔 4.3)	8	4.4	40	26	24	8
BRDN3010	6200ZZ			11				44	30		
BRDN2812	6001ZZ	10	42	28							
BRDN3212	6201ZZ	12	60	12	M 6×1 (底孔 5.2)	9.5	5.4	46	32	26	10
BRDN3215	6002ZZ	15	65	11				48	35	28	9
BRDN3515	6202ZZ			13	52	29	11				
BRDN4220	6004ZZ	20	80	14	M 8×1.25 (底孔 6.8)	11	6.5	64	42	36	12
BRDN4720	6204ZZ		85	16				40	14		
BRDN4725	6005ZZ	25	90	14	M10×1.5 (底孔 8.5)	14	8.6	72	47	41	12
BRDN5225	6205ZZ		100	17				15	78	52	45
BRDN5530	6006ZZ	80							55	48	13
BRDN6230	6206ZZ	30	105	18				88	62	55	16

型号	质量 (g)
BRDN2610	170
BRDN3010	180
BRDN2812	160
BRDN3212	240
BRDN3215	250
BRDN3515	290
BRDN4220	480
BRDN4720	620
BRDN4725	580
BRDN5225	900
BRDN5530	770
BRDN6230	1030

使用示例及使用方法

- 使用示例及使用方法，注意事项等请参照“轴承固定座”。
- 安装方法请参照“轴承固定座的装拆方法”。