

BK2,DK2,FK2

OK夹钳(全螺纹螺栓用套)

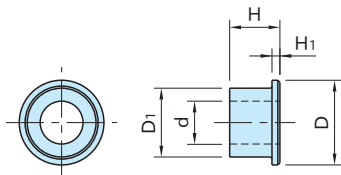

本体
钢铁
HRC48~52

型号	D ₁	d	H	D	H ₁	适用螺栓	质量 (g)	适用OK夹钳
BK2-BB2	13	8.1	9.5	16	1.5	M 8	7	BK2
DK2-DB2	18	12.3	14	22.5	1.8	M12	17	DK2(不包括双型)
FK2-FB2	24.8	16.5	17	31	2	M16	40	FK2(不包括双型)

使用示例及使用方法

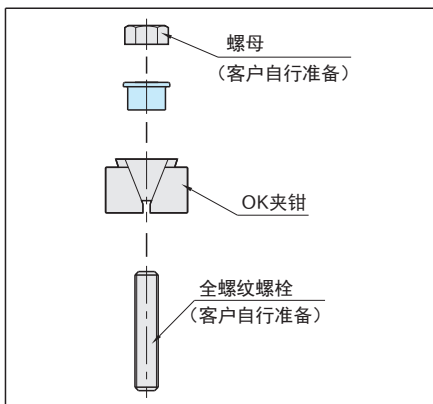
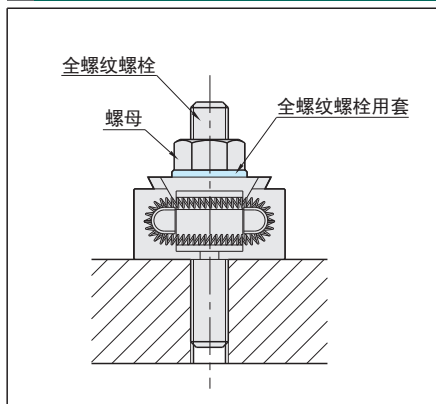

把全螺纹螺栓固定在金属板的螺丝孔里面后，按照OK夹钳、全螺纹螺栓用套、螺母的顺序安装。然后，用扳手等旋转螺母，进行夹紧/松开的操作。
注)OK夹钳是另售品。

