

BJ156-B

成套内槽圆头压板(B型)

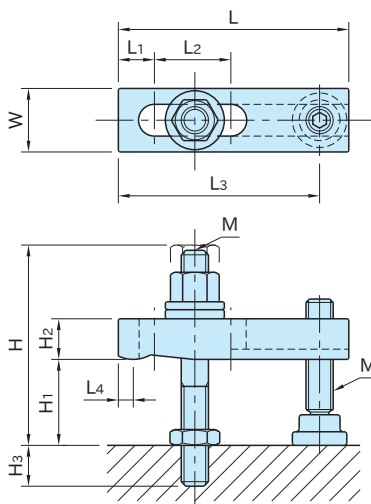

双头螺栓	其它
SCM435 淬火回火 四氧化三铁膜	S45C 淬火回火 四氧化三铁膜

型 号	H ₁	L	W	H _{max.}	M	H ₃	L ₂	L ₁	L ₃	L ₄	H ₂	夹紧力(kN) 突出量 max.~min.	容许紧固扭矩 (N·m)	质量 (kg)	
BJ156-08050B1	20~35	50		64	M 8x1.25	16	14	12	42		12	4 ~ 7.6	17	0.14	
BJ156-08050B2	35~55			81		20								0.15	
BJ156-08050B3	60~75			105		20								0.17	
BJ156-08063B1	20~35	63	19	64	M 8x1.25	16	27	55	5		12	3.1~ 8.3	17	0.15	
BJ156-08063B2	35~55			81		20								0.16	
BJ156-08063B3	60~75			105		20								0.18	
BJ156-08080B1	15~35	80		65	M 10x1.5	16	34	15	72		16	3.4~ 8.4	17	0.2	
BJ156-08080B2	30~50			80		20								0.21	
BJ156-08080B3	55~75			105		20								0.23	
BJ156-10063B1	25~50	63		80	M 10x1.5	20	18	53		12	6.4~12.2	34	45	0.25	
BJ156-10063B2	50~80			109										20	0.28
BJ156-10080B1	25~50			83										25	M10x1.5
BJ156-10080B2	50~75	108	20	0.34											
BJ156-10100B1	20~45	81	100	M10x1.5	20	40	90	5	16	7.4~17.7	45	0.41			
BJ156-10100B2	45~75	111										20	0.45		

型 号	H ₁	L	W	H max.	M	H ₃	L ₂	L ₁	L ₃	L ₄	H ₂	夹紧力(kN) 突出量 max.~min.	容许紧固扭矩 (N·m)	质量 (kg)
BJ156-12063B1	25~50	63		86	M12×1.75	18	14	14	52		16	13.7~21.6	71	0.39
BJ156-12063B2	50~70			107		0.43								
BJ156-12063B3	80~105			141		0.49								
BJ156-12080B1	25~50	80		86		18	25		69			10.3~21		0.43
BJ156-12080B2	50~70			107		0.47								
BJ156-12080B3	80~105			141		0.53								
BJ156-12100B1	20~45	100	32	84		18	40		89	6	19	10.9~25.8	80	0.57
BJ156-12100B2	45~70			109		0.63								
BJ156-12100B3	75~100			139		0.64								
BJ156-12125B1	20~45	125		84		18	50		114			12.9~27.5		0.68
BJ156-12125B2	45~70			109		0.74								
BJ156-12125B3	75~100			139		0.96								
BJ156-12160B1	15~40	160		85	18	60		149		25	17.4~32.5	90	1	
BJ156-12160B2	40~65			110	1.06									
BJ156-12160B3	70~95			140	1.18									
BJ156-16080B1	40~60	80		106	24	17	18	65		19	16.6~26	115	1.33	
BJ156-16080B2	65~90			136	1.47									
BJ156-16080B3	95~130			176	1.35									
BJ156-16100B1	35~60	100		109	24	30		85	6	22	12.7~25.3		1.5	
BJ156-16100B2	60~90			139	1.64									
BJ156-16100B3	95~125			174	1.52									
BJ156-16125B1	35~55	125	38	107	24	45	25	110		25	14.7~31.1	129	1.67	
BJ156-16125B2	60~90			142	1.81									
BJ156-16125B3	90~125			177	1.71									
BJ156-16160B1	35~55	160		107	24	65		145		25	15.3~33.4		1.86	
BJ156-16160B2	60~90			142	2									
BJ156-16160B3	90~125			177	2									

使用示例及使用方法

