

BJ153-A

成套内槽压板(A型)

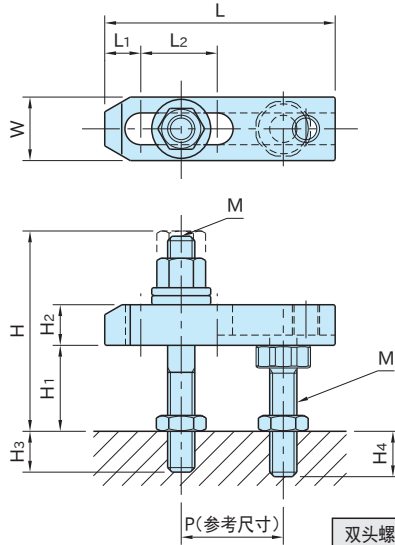
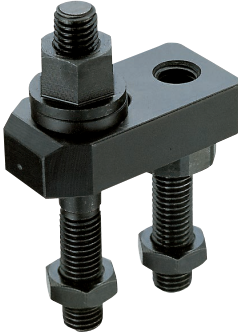

双头螺栓	其它
SCM435 淬火回火 四氧化三铁膜	S45C 淬火回火 四氧化三铁膜

型 号	H ₁	L	W	H max.	M	L ₂	H ₃	H ₄	P	L ₁	H ₂	夹紧力(kN) 突出量 max.~min.	容许紧固扭矩 (N·m)	质量 (kg)
BJ153-08040A1	15~25	40	19	51	M 8X1.25	6	12	22~12	20	10	12	5.9~ 7.1	17	0.12
BJ153-08040A2	20~35			66		14	27~12	0.14						
BJ153-08050A1	15~25	50	19	51	M 8X1.25	14	12	22~12	20	12	12	4.6~ 6.6	17	0.13
BJ153-08050A2	20~35			66		14	27~12	0.15						
BJ153-08063A1	15~25	63	19	51	M 8X1.25	27	12	22~12	20	12	12	3.6~ 6.6	17	0.14
BJ153-08063A2	20~35			66		14	27~12	0.16						
BJ153-10050A1	20~30	50	25	62	M10X1.5	8	18	20~10	25	12	12	9.4~11.5	34	0.21
BJ153-10050A2	25~45			80		20	30~10	0.23						
BJ153-10063A1	20~30	63	25	62	M10X1.5	18	18	20~10	30	15	12	7.3~10.6	34	0.23
BJ153-10063A2	25~45			80		20	30~10	0.25						
BJ153-10080A1	20~30	80	25	63	M10X1.5	32	18	20~10	30	15	16	8.8~15	45	0.3
BJ153-10080A2	25~45			80		20	30~10	0.32						
BJ153-10100A1	20~30	100	25	63	M10X1.5	40	18	20~10	40	16	16	9.5~16.4	45	0.35
BJ153-10100A2	25~45			80		20	30~10	0.37						
BJ153-10125A1	20~30	125	25	63	M10X1.5	50	18	20~10	55	16	16	10.3~17.7	45	0.41
BJ153-10125A2	25~45			80		20	30~10	0.43						

型号	H ₁	L	W	H max.	M	L ₂	H ₃	H ₄	P	L ₁	H ₂	夹紧力(kN) 突出量 max.~min.	容许紧固扭矩 (N·m)	质量 (kg)	
BJ153-12063A1	20~40	63		80		14	20	33~13		14	16	15.3~20.2	71	0.38	
BJ153-12063A2	45~55			101		24	23~13	30				0.42			
BJ153-12080A1	20~40	80		80		25	20		33~13	11.8~17.8		0.43			
BJ153-12080A2	45~55			101			24	23~13	0.47						
BJ153-12100A1	20~40	100	32	80	M12×1.75	40	20	33~13	35	20	19	12.3~21.2	80	0.54	
BJ153-12100A2	40~55			101			24	28~13				0.58			
BJ153-12125A1	20~40	125		80		50	20	33~13	50	13.9~23.8		0.63			
BJ153-12125A2	40~55			101			24	28~13		0.67					
BJ153-12160A1	20~40	160	80	60	20	33~13	75	16.1~26.3	0.76						
BJ153-12160A2	40~55		101			24				28~13	0.8				
BJ153-16080A1	25~35	80	38	81		17	20	28~18	40	18	19	14.7~24.8	115	0.72	
BJ153-16080A2	35~50			96			30	33~18				0.77			
BJ153-16100A1	25~35	100		87		30	20	28~18	25	25		15.4~24.8		129	0.94
BJ153-16100A2	35~50			102			24	33~18							0.99
BJ153-16125A1	25~35	125	87	45	20	28~18	50	16.1~26.9	1.07						
BJ153-16125A2	35~50		102		24	33~18				1.12					
BJ153-16160A1	25~35	160	87	65	20	28~18	65	16.9~29.1	1.25						
BJ153-16160A2	35~50		102		24	33~18				1.3					
BJ153-20160A1	45~70	160	50	130	M20×2.5	60	36	45~20	60	32	25	18.1~29.8	183	2	
BJ153-20200A1	200	80				80		19.1~32.7				2.3			

使用示例及使用方法

