

BJ130

钩形夹具



WEB 产品视频公布



M8型



M10 ~ M16型

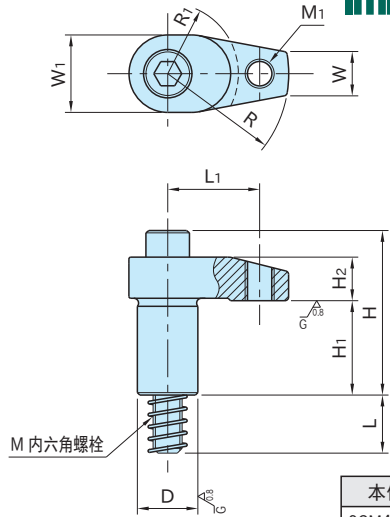

本体
SCM435
淬火回火
四氧化三铁膜
精密研磨

★One Point
省空间型夹具

相关产品页

还备有 **BJ530** 钩柄。(参照P.374)

使用示例及使用方法

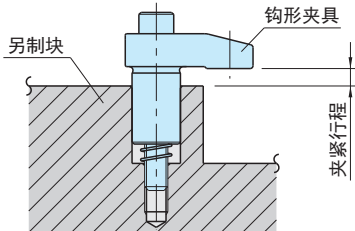

- BJ130-08*** (M 8尺寸) ... 行程10mm
- BJ130-10*** (M10尺寸) ... 行程12mm
- BJ130-12*** (M12尺寸) ... 行程15mm
- BJ130-16*** (M16尺寸) ... 行程15mm

■另制块的加工方法

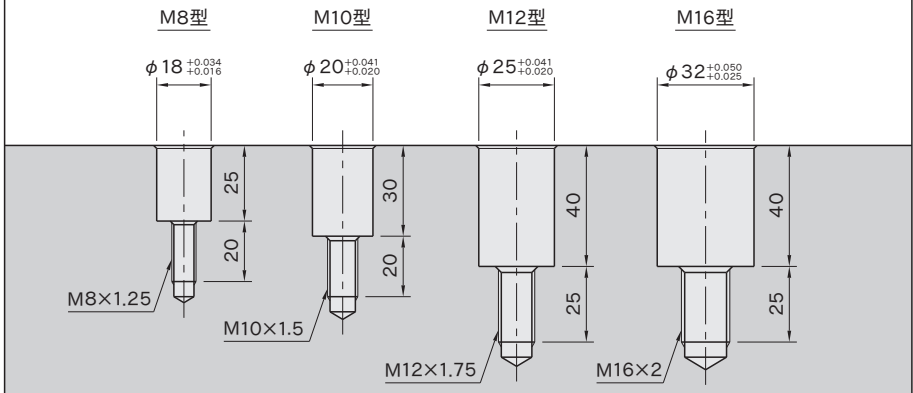

在另制块上嵌入使用钩形夹具时，请按上图尺寸加工。

型 号	R	R ₁	M ₁	L ₁	D (h7)	H ₁	M	L	H		
BJ130-08020	20	15	-	-	18	23	M 8×1.25-50L	21	37		
BJ130-08025	25										
BJ130-08030	30										
BJ130-10030	30	20	-	-	20	30	M10×1.5 -65L	21	54		
BJ130-10040	40										
BJ130-12040	40	25	-	-	25	39	M12×1.75-80L	26	66		
BJ130-12050	50							24	68		
BJ130-12060	60							M12×1.75	31	26	66
BJ130-12140	40								38		
BJ130-12150	50								46		
BJ130-12160	60							24	68		
BJ130-16040	40							25	-	-	32
BJ130-16050	50										
BJ130-16060	60										
BJ130-16150	50	M12×1.75	38								
BJ130-16160	60		46								

型 号	W ₁	W	H ₂	夹紧力 (kN)	容许紧固扭矩 (N·m)注)	质量 (g)
BJ130-08020	22	10	12	15	38	90
BJ130-08025				12	33	100
BJ130-08030				10	30	105
BJ130-10030	25	12	15	13	38	165
BJ130-10040				10	32	180
BJ130-12040	32	18	16	18	60	305
BJ130-12050				14	50	360
BJ130-12060			12	46	380	
BJ130-12140			16	60	295	
BJ130-12150			18	14	50	350
BJ130-12160				12	46	370
BJ130-16040	36	22	21	38	170	530
BJ130-16050				31	150	580
BJ130-16060				26	130	625
BJ130-16150				31	150	565
BJ130-16160				26	130	610

注)在另制块中使用时的容许紧固扭矩。

与[BJ530]钩柄配套使用时,请参照[BJ530]钩柄的容许紧固扭矩。

(参照P.374)

注意事项

不使用切削液加工时,为了防止夹紧松开时的卡死,
请在产品滑动面涂抹润滑油。