

BJ130-A

フッククランプセット

標準 在庫品 

IMAO



M8タイプ



M12タイプ

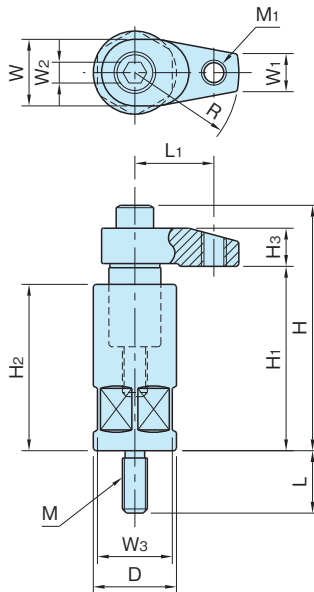

フック	ホルダー
SCM435 焼入焼戻 四三酸化鉄皮膜 研磨仕上	S45C 四三酸化鉄皮膜 研磨仕上

★One Point
省スペースのクランプです

品番	H ₁	M ₁	L ₁	R	D	H ₂	M	L	H
BJ130-08020A1	55~65	—	—	20	24	55	M 8×1.25	19	69~ 79
BJ130-08025A1				25					
BJ130-08030A1				30					
BJ130-10030A1	63~75	—	—	30	32	63	M12×1.75	30	87~ 99
BJ130-10030A2	80~92					80			104~116
BJ130-10040A1	63~75			63		87~ 99			
BJ130-10040A2	80~92			80		104~116			

品番	W	W ₁	H ₃	W ₂	W ₃	クランプ力 (kN)	許容締付トルク (N·m)	質量 (kg)	価格
BJ130-08020A1	22	10	12	6	22	12	30	0.23	6,800
BJ130-08025A1						11		0.24	6,900
BJ130-08030A1						10		0.25	7,000
BJ130-10030A1	25	12	15	8	30	13	38	0.60	8,300
BJ130-10030A2						10		0.70	8,400
BJ130-10040A1						10		0.61	9,100
BJ130-10040A2						10		0.71	9,200

関連製品ページ

高さ調整に[BJ600] ジョイントバーを用意しています。
(P. 1740 参照)

注意事項

乾式加工でご利用される場合、アンクランプ時のかじり防止の為、グリスを摺動面に塗布することをお勧めします。

使用例・使用方法

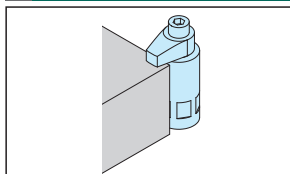

品番	H ₁	M ₁	L ₁	R	D	H ₂	M	L	H		
BJ130-12040A1	80~95	—	—	40	40	80	M12×1.75	30	107~122		
BJ130-12040A2	100~115					100			127~142		
BJ130-12050A1	80~95					80			109~124		
BJ130-12050A2	100~115			100		129~144					
BJ130-12060A1	80~95			60		109~124					
BJ130-12060A2	100~115			100		129~144					
BJ130-12140A1	80~95			M12×1.75		31			40	80	107~122
BJ130-12140A2	100~115									100	127~142
BJ130-12150A1	80~95									80	109~124
BJ130-12150A2	100~115					100			129~144		
BJ130-12160A1	80~95					46			60	80	109~124
BJ130-12160A2	100~115					100			129~144		
BJ130-16040A1	80~95	—	—	40	50	80	M16×2	30	116~131		
BJ130-16040A2	100~115					100			136~151		
BJ130-16050A1	80~95					80			116~131		
BJ130-16050A2	100~115			100		136~151					
BJ130-16060A1	80~95			60		116~131					
BJ130-16060A2	100~115			100		136~151					
BJ130-16150A1	80~95			M12×1.75		38			50	80	116~131
BJ130-16150A2	100~115									100	136~151
BJ130-16160A1	80~95									80	116~131
BJ130-16160A2	100~115					100			136~151		
BJ130-16160A1	80~95					46			60	80	116~131
BJ130-16160A2	100~115					100			136~151		

品番	W	W ₁	H ₃	W ₂	W ₃	クランプ力 (kN)	許容締付トルク (N·m)	質量 (kg)	価格			
BJ130-12040A1	32	18	16	10	36	15	50	1.36	10,200			
BJ130-12040A2						1.56		10,800				
BJ130-12050A1						1.39		10,700				
BJ130-12050A2			1.59			11,100						
BJ130-12060A1			18			10	12	46	1.43	10,900		
BJ130-12060A2									1.63	11,300		
BJ130-12140A1									1.36	10,700		
BJ130-12140A2			16			10	15	50	1.56	11,100		
BJ130-12150A1									1.39	11,200		
BJ130-12150A2									1.59	11,700		
BJ130-12160A1			18			10	12	46	1.43	11,300		
BJ130-12160A2									1.63	11,800		
BJ130-16040A1	2.11	13,400										
BJ130-16040A2	2.42	13,800										
BJ130-16050A1	36	22	21	14	46	18	80	2.16	14,100			
BJ130-16050A2						16.5		2.47	14,700			
BJ130-16060A1						16		2.22	14,700			
BJ130-16060A2						2.53		14,700				
BJ130-16150A1						16.5		16	16.5	80	2.16	14,700
BJ130-16150A2											2.47	15,200
BJ130-16160A1											2.22	15,200
BJ130-16160A2						16		2.53	15,800			