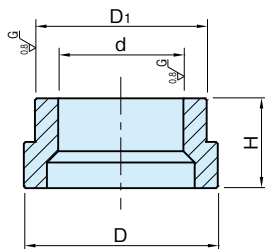
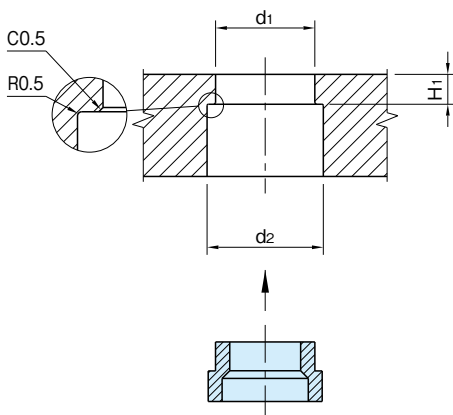

BB1**リバースマウントブッシュ**標準 **在庫品** **RHS****Jergens****本体**

SNCM439
焼入焼戻
四三酸化鉄皮膜
研磨仕上
HRC50~54

品番	d	D	D ₁ (+0.04)	H	質量 (g)	適用フランジヤク (P.1966、1967参照)
BB1-13	13	25	20	12.1	20	BS1-13
BB1-16	16	28.6	22			BS1-16
BB1-20	20	32.2	28	17.1	50	BS1-20
BB1-25	25	40.2	35	21	80	BS1-25

使用例・使用方法**■穴加工図**

品番	d ₁ (+0.025 +0.015)	d ₂	H ₁ (±0.05)
BB1-13	20	26	6.92
BB1-16	22	29	7.24
BB1-20	28	33	8.74
BB1-25	35	41	10.54

