

QUICK-CHANGE FIXTURING SYSTEM

Features:

1. Allows speeding up fixture change with accuracy.
2. Allows mounting the same fixture on different machines.
3. Allows machining a part from five sides on one fixture.
4. Allows setting up fixtures without loss of time.

Quick Fixture-Plate Locating Method

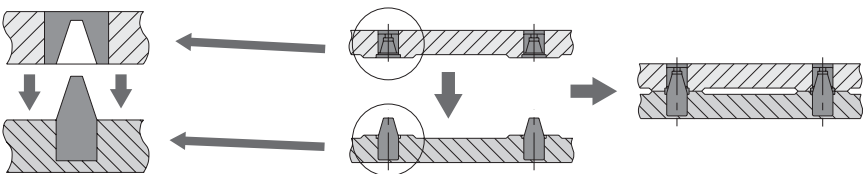

Two tapered pins on the Flex Base Plate mate with the receiver bushings in the Flex Fixture Plate or Flex Angle Plate, to ensure excellent locating repeatability.

PLATE COMBINATION

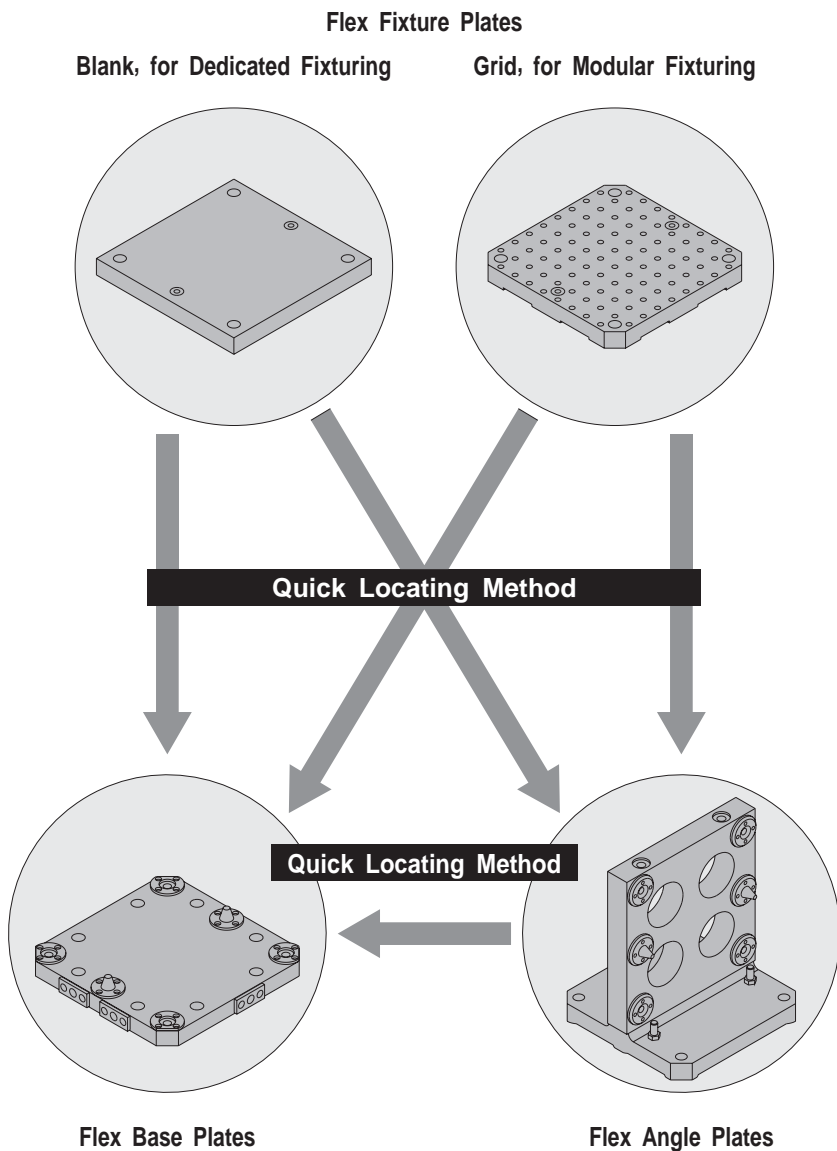

Modular
Fixture Bases

Blank
Fixture Bases

Quick-Change
Fixture Bases

Standard
Fixture Parts

Modular
Fixture Parts

One-Touch
Clamps

FEATURES

1 Speedy and Accurate Fixture Change:

- Two tapered pins allow simply locating a Flex Fixture Plate or Flex Angle Plate on a Flex Base Plate.
- A Flex Fixture Plate or Flex Angle Plate sits on a Flex Base Plate with minimal contact area, which allows easy cleaning in changing fixtures.

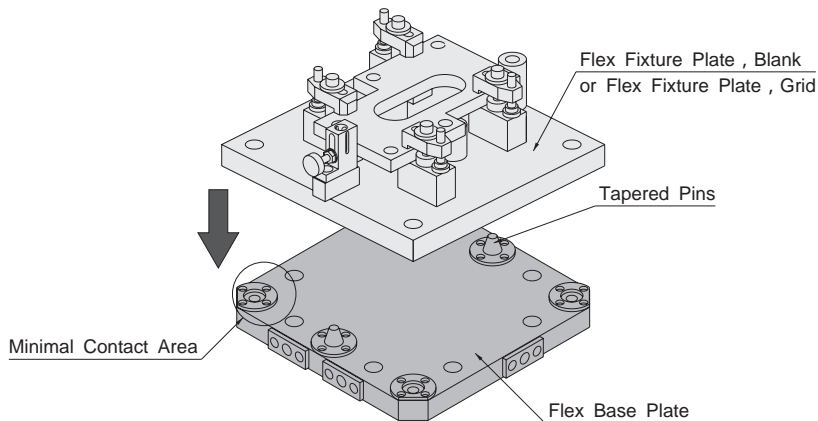
**2 Flexible Mounting on Different Machines:**

- Once a Flex Base Plate is installed on different machines, the same fixture can mount on any of those machines.

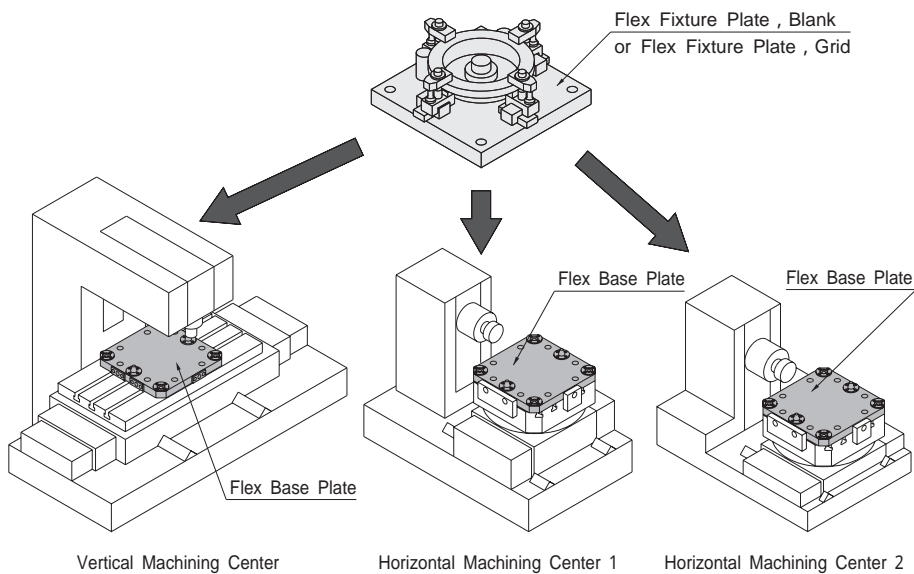

FEATURES

3 Machining from Five Sides:

- Using a Flex Angle Plate together allows mounting the same fixture horizontally and vertically on the same pallet for machining from five sides (centering is not needed when the fixture is turned over).

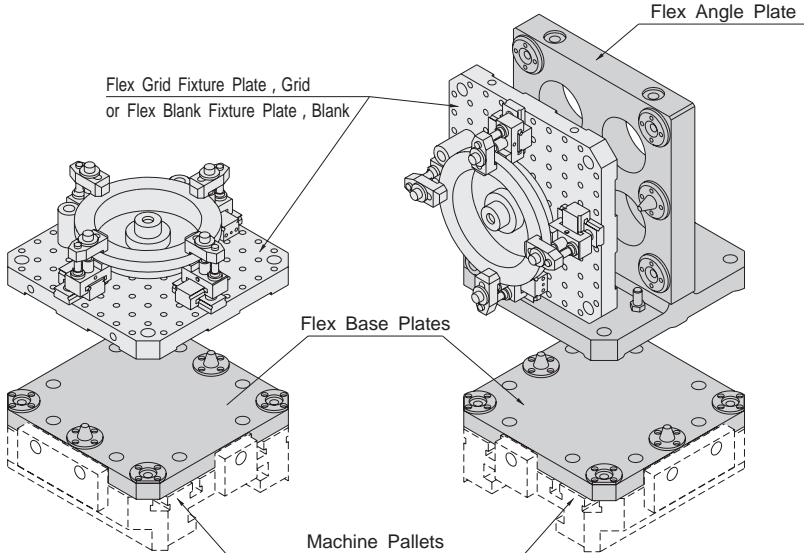
**4 No Time loss In Fixture Setup:**

- No need for fixture centering allows instantly getting repeatedly-used fixtures ready for machining whenever necessary.

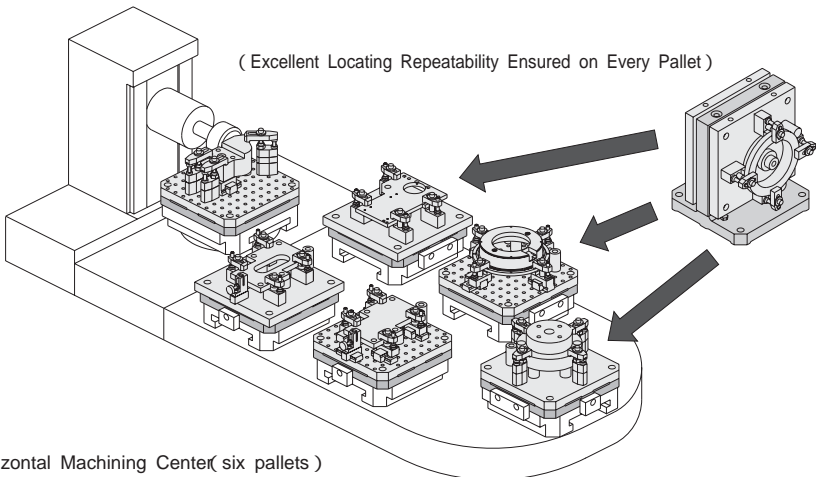

FJ01-N

FLEX BASE PLATES

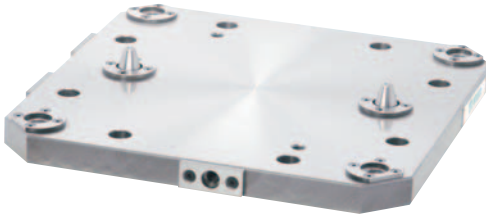

[Body]

Material:FC250 cast iron
 Annealed
 Precision ground

[Rest Pads]

Material:S45C steel
 Heat Treated
 Precision ground

[Tapered Pins]

Material:SK95 steel
 Heat Treated
 Precision ground

Also available with DIN mounting capability or in other specified designs on request.

FJ01-4040N

FJ01-5050N

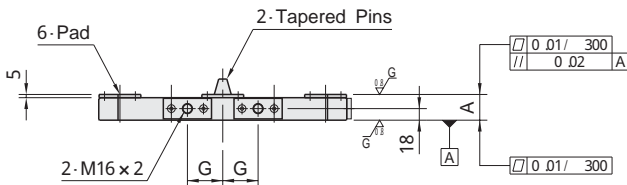
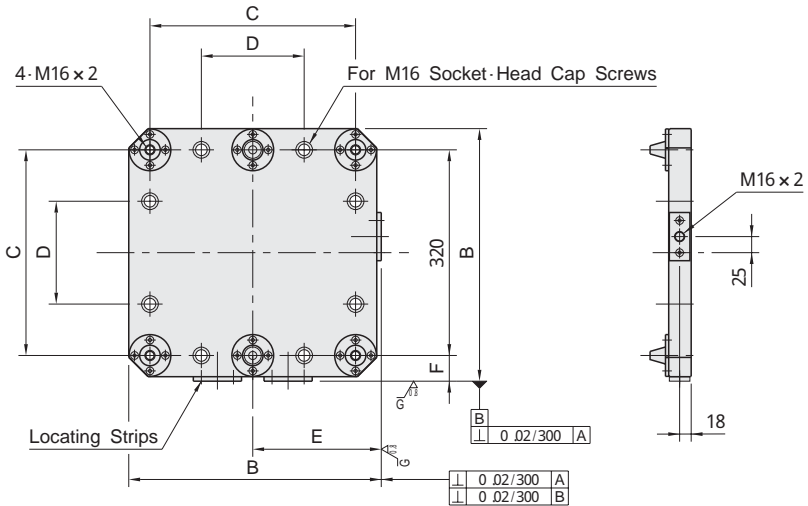

FJ01-6363N
FJ01-8080N

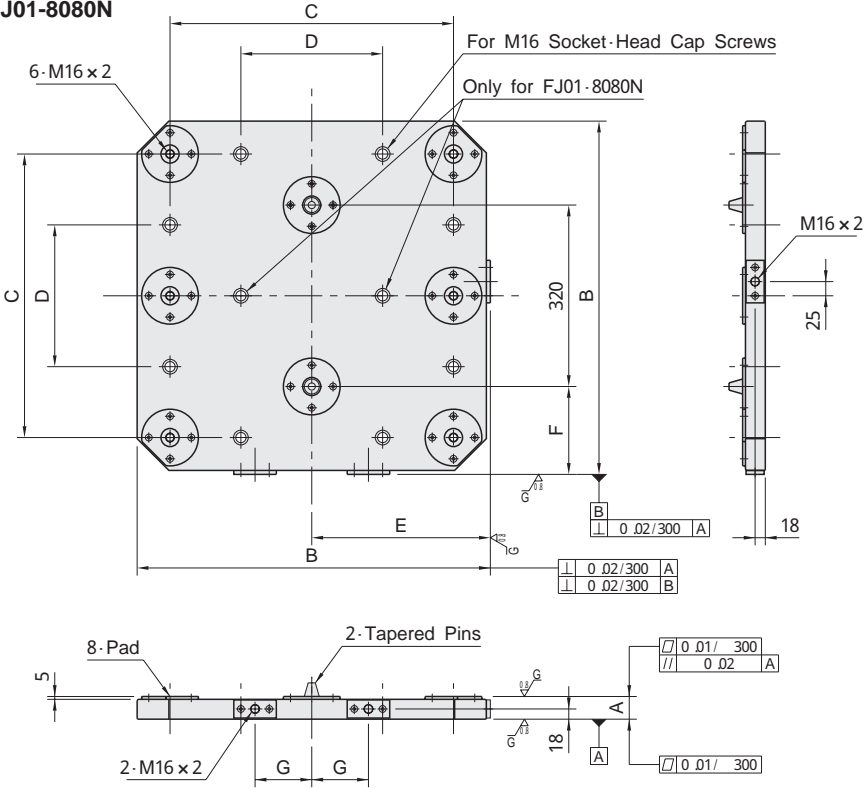

Part Number	Pallet Size	A (±0.02)	B	C	D	E (±0.04)	F (±0.04)	G	No. of Mounting Holes	Weight (kg)
FJ01-4040N	400	40	393	320	160	200	40	55	8	42
FJ01-5050N	500	40	493	400	200	250	90	75	8	66
FJ01-6363N	630	40	623	500	250	315	155	100	8	106
FJ01-8080N	800	45	793	640	320	400	240	135	10	171

- Eye bolts are included.
- Flex Base Plates are designed to mount on the machining-center pallet to JIS B 6337 standard.

FJ05

FLEX ANGLE PLATES



[Body]
Material:FC300 cast iron
Annealed
Precision machined

[Rest Pads]
Material:S45C steel
Heat treated
Precision ground

[Tapered Pins/Receiver Bushings]
Material:SK95 steel
Heat treated
Precision ground

FJ05-4040

FJ05-5050

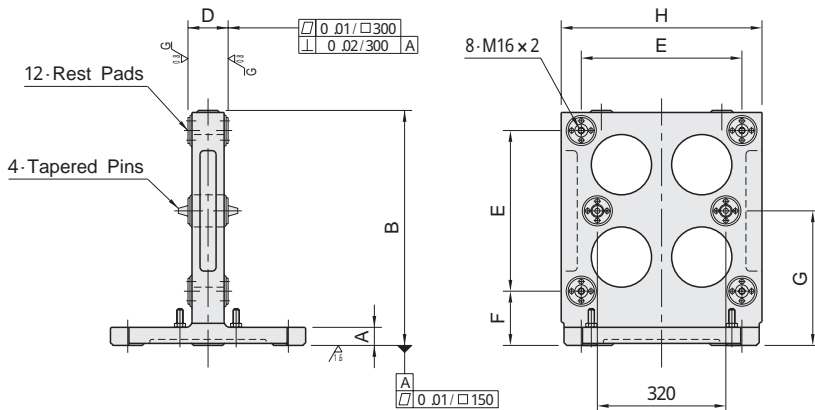
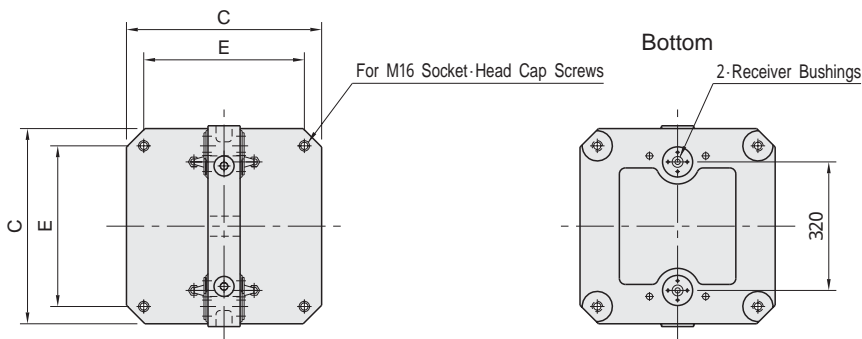

Modular
Fixture Bases

Blank
Fixture Bases

Quick-Change
Fixture Bases

Standard
Fixture Parts

Modular
Fixture Parts

One-Touch
Clamps

FJ05-6363
FJ05-8080

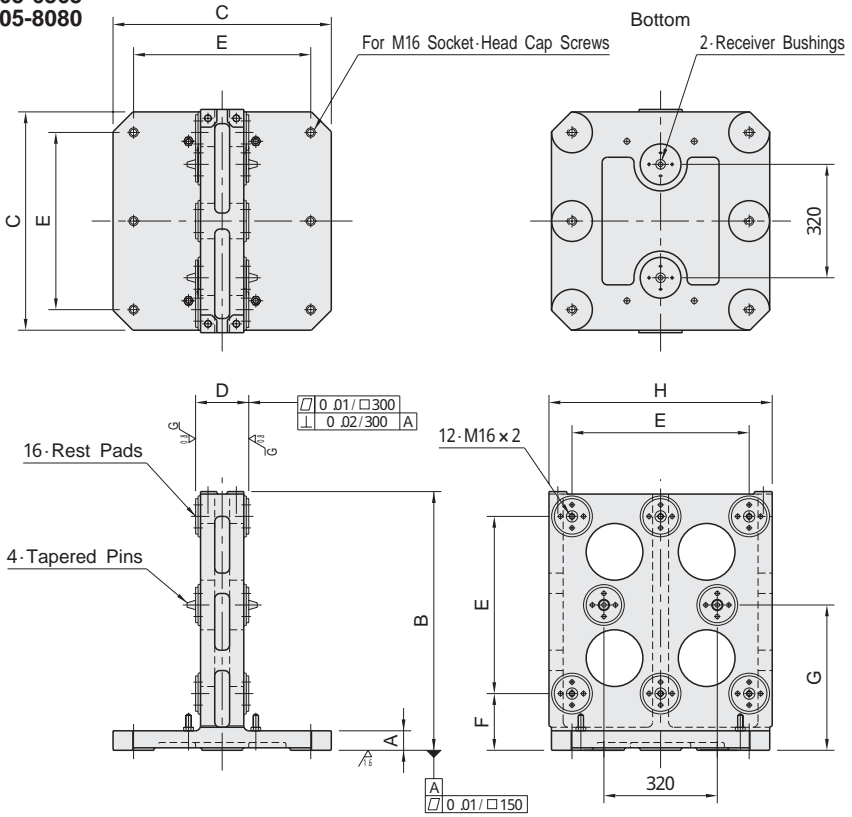

Part Number	A	B	C	D (±0.04)	E	F	G (±0.04)	H	No. of Mounting Holes	Weight (kg)
FJ05-4040	40	465	386	80	320	100	260	400	4	96
FJ05-5050	45	585	486	100	400	135	335	500	4	188
FJ05-6363	55	730	616	150	500	160	410	630	6	353
FJ05-8080	60	930	786	200	640	210	530	800	6	644

- Eye bolts are included.
- Subplate that mounts on the Flex Base Plate and accepts Flex Fixture Plates.

FJ10(Standard&Heavy) FLEX GRID FIXTURE PLATES



- [Body]
Material:FC250 cast iron
Annealed
Precision ground
- [Receiver Bushings]
Material:SK95 steel
Heat treated
Precision ground
- [Alignment Bushing]
Material:SUJ2 steel
Heat treated
- [Threaded Insert]
Material:S45C steel
Nitrocarburized

FJ10-4040-12/16
FJ10-5050-12/16

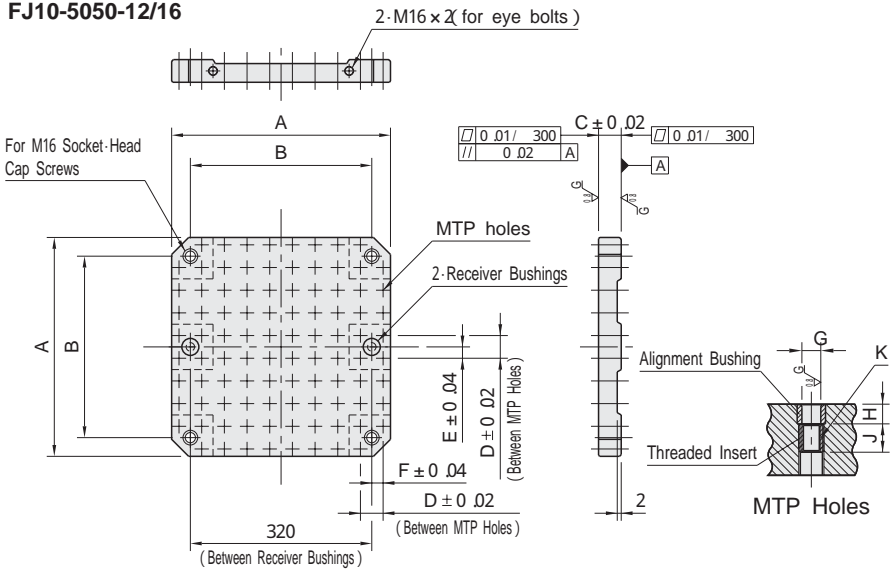

Part Number	A	B	C	D	E	F	G (F7)	H	J	K	No. of MTP Holes	No. of Mounting Holes	Weight (kg)
FJ10-4040-12	386	320	40	50	25	15	12	12.5	15	M12 x 1.75	60	4	38
FJ10-4040-16				50	25	15	16	16.5	18	M16 x 2			37
FJ10-5050-12	486	400	40	50	25	15	12	12.5	15	M12 x 1.75	96	4	60
FJ10-5050-16				50	25	15	16	16.5	18	M16 x 2			96

Modular
Fixture Bases

Blank
Fixture Bases

Quick-Change
Fixture Bases

Standard
Fixture Parts

Modular
Fixture Parts

One-Touch
Clamps

FJ10-6363-12 FJ10-6363-16
FJ10-8080-12 FJ10-8080-16

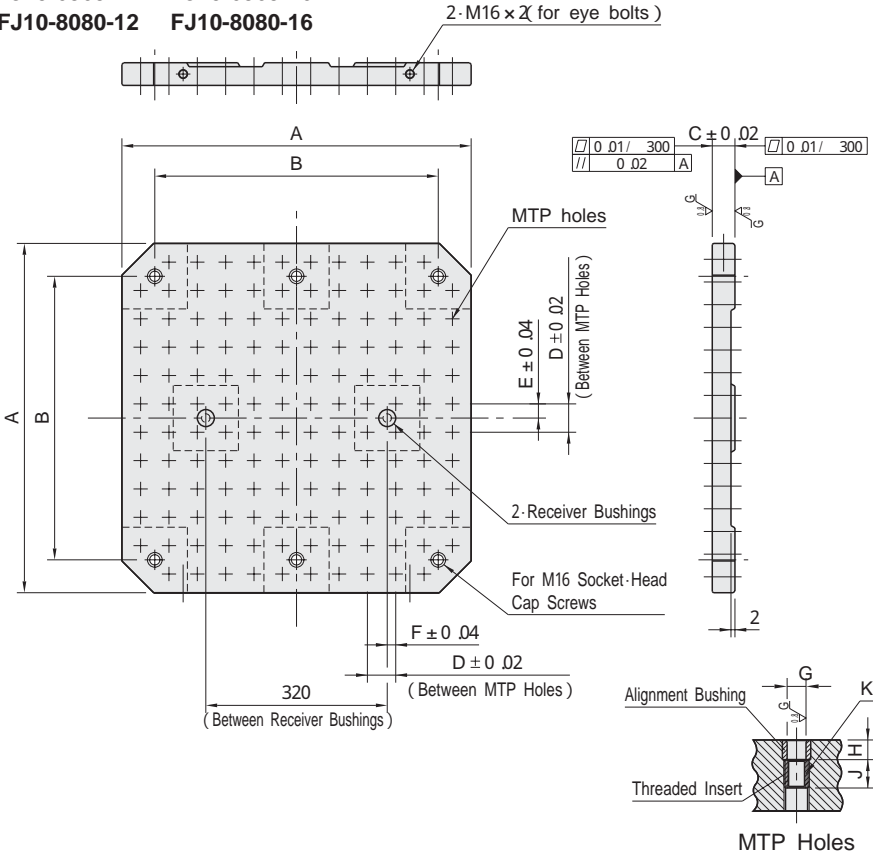

品番	A	B	C	D	E	F	G (F7)	H	J	K	No. of MTP Holes	No. of Mounting Holes	Weight (kg)
FJ10-6363-12	616	500	40	50	25	15	12	12.5	15	M12 × 1.75	140	6	98
FJ10-6363-16							16	16.5	18	M16 × 2			95
FJ10-8080-12	786	640	45	50	25	15	12	12.5	15	M12 × 1.75	240	6	158
FJ10-8080-16							16	16.5	18	M16 × 2			153

- MTP-hole protection plugs and eye bolts are included.
- Every MTP hole is marked with an address number and letter.
- Fixture plate that mounts on the Flex Base Plate or Flex Angle Plate .
- MTP holes spacing : $50 \pm 0.02\text{mm}$

FJ12

FLEX BLANK FIXTURE PLATES

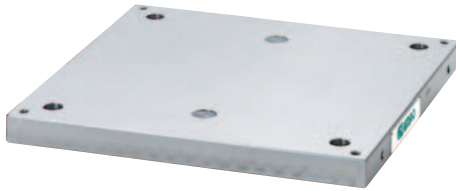

[Body]

Material:S50C steel
Precision ground

[Receiver Bushings]

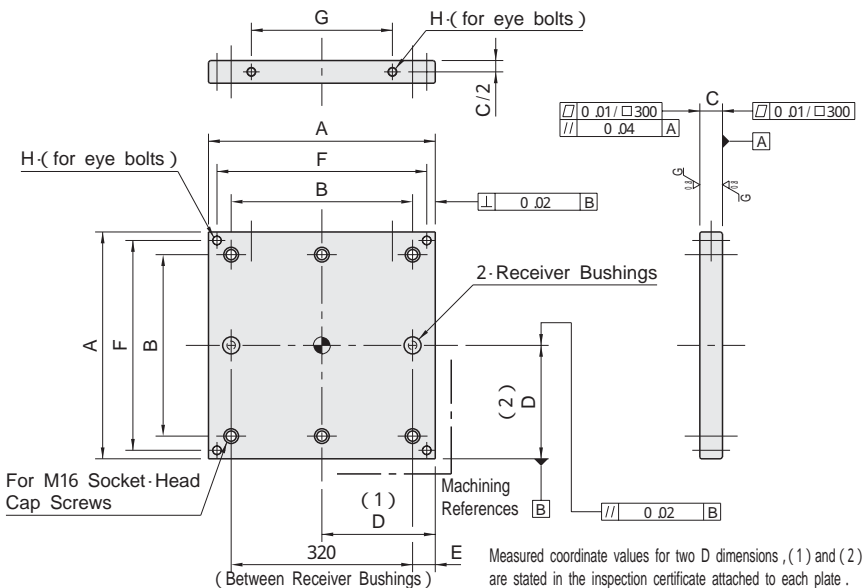
Material:SK95 steel
Heat treated
Precision ground

Part Number	A	B	C ($^{+0.30}$ $^{-0.35}$)	D (± 0.1)	E	F	G	H	No. of Mounting Holes	Weight (kg)
FJ12-4040-00	400	320	40	200	40	370	280	M16 x 2	4	50
FJ12-5050-00	500	400	40	250	90	460	350			78
FJ12-6363-00	630	500	40	315	155	540	460	M16 x 2	6	124
FJ12-8080-00	800	640	45	400	240	680	570			225

Note: Do not grind the bottom of the Flex Blank Fixture Plate to preserve the accurate fit of its receiver bushings with the tapered pins of the subplate.

- Eye bolts are included.
- Blank fixture plate for dedicated fixturing that mounts on the Flex Base Plate or Flex Angle Plate.
- Machining references are provided for better machining.